

WOOD | TOP ABETE | TOP CORTECCIA | METALLO

COLLEZIONE BAGNO
INDUSTRIAL **STYLE**
FACTORY



- **STRUTTURA IN ABETE MASSICCIO**

SOLID TIR WOODEN STRUCTURE | STRUCTURE EN SAPIN MASSIF
STRUKTUR AUS MASSIVEM TANNENHOLZ | EXSTRUCTURA DE MADERA MACIZA DE ABETO

- **CONTENITORI CON FRONTALE SQUADRATO**

PLAIN DOOR ELEMENTS | ÉLÉMENTS AVEC PORTE CARRÉE
ELEMENTEN MIT VOLLTÜR | MÓDULOS CON PUERTA CUADRADA

- **TOP IN ABETE MASSICCIO**

SOLID TIR WOODEN TOP | PLAN DE TOILETTE EN SAPIN MASSIF
WASCHTISCHPLATTE AUS MASSIVEM TANNENHOLZ | ENCIMERA DE ABETO MACIZO

- **TOP IN ROVERE MASSICCIO
CON BORDO FRONTALE CORTECCIA**

SOLID OAK WOODEN TOP WITH BARK-LIKE FRONTAL EDGE
PLAN DE TOILETTE EN CHÊNE MASSIF AVEC BORD FRONTAL EFFET ÉCORCE BRUTE
WASCHTISCHPLATTE AUS MASSIVEM EICHENHOLZ MIT VONDERKANTE ALS RINDE
ENCIMERA DE ROBLE MACIZO CON ORILLO FRONTAL SIMILAR CORTEZA

- **ACCESSORI IN METALLO**

METAL COMPLEMENTS | COMPLEMENTS EN MÉTAL
KOMPLEMENTE AUS METAL | COMPLEMENTOS DE METAL



WOOD



TOP ABETE



TOP CORTECCIA



METALLO

• I MATERIALI _ ABETE

OUR MATERIALS _ "ABETE" - LES MATÉRIAUX_ABETE - DIE MATERIALIEN _ FICHTE - LOS MATERIALES _ ABETO

I top e le strutture RING in legno massiccio di ABETE sono realizzati con tavolame di recupero in finitura "PRIMA PATINA" proveniente da cantieri industriali. La provenienza e l'uso che ne è stato fatto nel tempo conferiscono alla superficie di questi piani un aspetto vissuto e irregolare; possono presentare infatti, discromie, stuccature, bruciature o residui cementizi. Sono disponibili in 2 tinte : NATURALE e SBIANCATO e con 3 tipologie di spessore e bordi diverse.

"ABETE" wooden tops and "RING" carcasses are made from recycled timber with a "Prima Patina" finish taken from industrial building yards. Their origin and how they have been used in the past give the surfaces of these tops a worn, irregular appearance. In fact, they may feature uneven colouring, holes filled with plaster, burn marks or areas partially covered with cement. Two shades are available: NATURALE or SBIANCATO in 3 different thicknesses and edges.

Les plans de toilette et les structures RING en ABETE sont réalisés avec des planches de récupération en sapin massif provenant de chantiers industriels et ont une finition « PRIMA PATINA ». Leur provenance et l'usage qu'on en a fait donnent à la surface de ces plans un aspect vécu et irrégulier dérivant de tonalités différentes, de rebouchages, de brûlures ou des résidus de ciment. Ils existent en 2 teintes au choix : NATURALE et SBIANCATO et peuvent avoir 3 types d'épaisseur et de chant.

Die Waschtischplatten und die Strukturen RING aus massivem FICHTENHOLZ werden aus wiederverwerteten, aus Industrieanlagen stammenden Holzbrettern in Ausführung "Prima Patina" hergestellt. Die Herkunft und die jahrelange Verwendung verleihen der Oberfläche dieser Holzplatten ein abgenutztes und unregelmäßiges Aussehen. Sie können daher Farbabweichungen, Kittstellen, Brandspuren oder Zementreste aufweisen. Sie sind in 2 Farben lieferbar: NATURALE und SBIANCATO in 3 Stärken und mit verschiedenen Kantenausführungen.

Las encimeras y estructuras RING en madera maciza de ABETO están realizadas con tablas recuperadas con acabado "PRIMA PATINA" procedente de obras. La procedencia y el uso que se hizo a lo largo del tiempo confieren a la superficie de estas encimeras un aspecto usado e irregular: de hecho pueden tener manchas, estuque, quemaduras o residuos de cemento. Están disponibles en 2 tonalidades: NATURALE y SBIANCATO y con 3 tipos distintos de espesor y cantos.



• LE FINITURE _ ABETE

FINISHES - FINITIONS - OBERFLÄCHEN FERTIGUNGEN - ACABADOS

ABETE NATURALE



ABETE SBIANCATO



• VISTA LATERALE TOP

TOP LATERAL VIEW - BORD LATERAL PLAN DE TOILETTE - TISCHPLATTE SEITE - ORILLO LATERAL DE ENCIMERA



• STRUTTURA "RING"

"RING" STRUCTURE - STRUCTURE "RING" - STRUKTUR "RING" - ESTRUCTURA "RING"

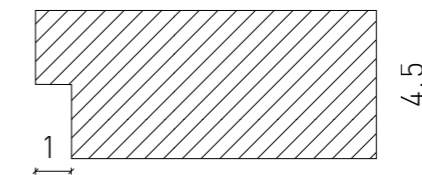

- **STRUTTURA IN ABETE MASSICCIO**

SOLID TIR WOODEN STRUCTURE | STRUCTURE EN SAPIN MASSIF
STRUKTUR AUS MASSIVEM TANNENHOLZ | EXSTRUCTURA DE MADERA MACIZA DE ABETO

- **CONTENITORI CON FRONTALE QUADRATO**

PLAIN DOOR ELEMENTS | ÉLÉMENTS AVEC PORTE CARRÉE
ELEMENTEN MIT VOLLTÜR | MÓDULOS CON PUERTA CUADRADA

WOOD

• FINITURE _ WOOD

FINISHES - FINITIONS - OBERFLÄCHEN FERTIGUNGEN - ACABADOS

LACCATO OPACO E LUCIDO

MATT AND GLOSS LACQUERED - LACQUÉE MAT ET BRILLIANT - MATT ODER GLÄNZEND LACKIERT - LACADO MATE Y BRILLO

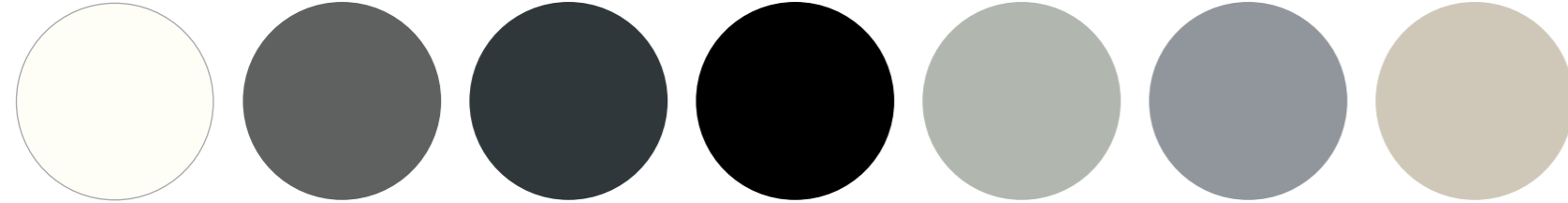

BIANCO 01 GRAFITE 02 FERRO 03 NERO 04 CENERE 06 FINESTRA 08 JUTA 60

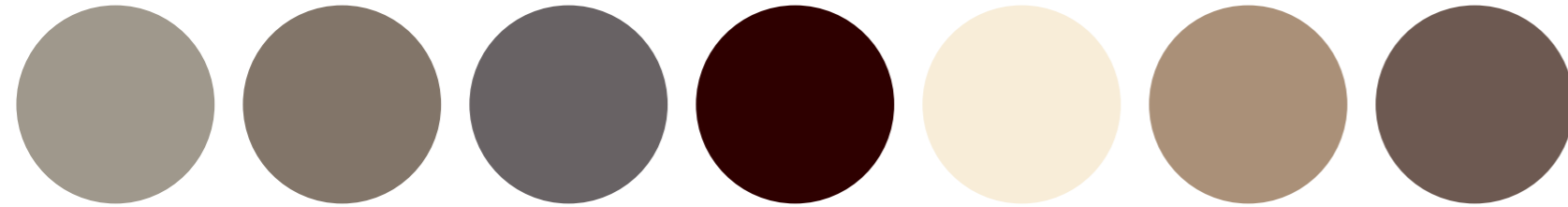

CANAPA 61 LIQUIRIZIA 62 FANGO 63 CACAO 64 BEIGE 10 BISCOTTO 13 TERRA 14

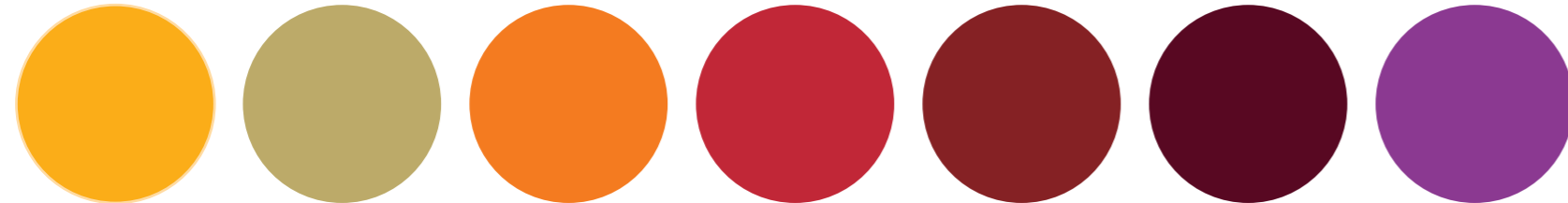

ZAFFERANO 15 AMBRA 16 ARANCIO 25 ROSSO 23 BORDEAUX 24 ROSSO INDIA 26 CICLAMINO 28

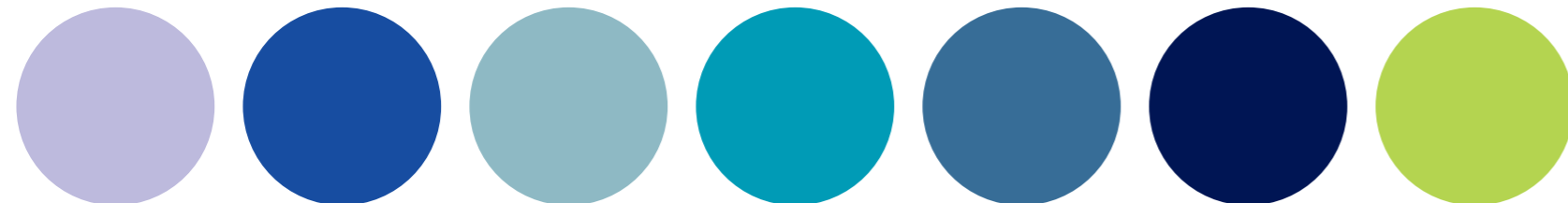

GLICINE 50 INDACO 52 POLVERE 46 MARE 45 AVIO 44 COBALTO 43 VERDE ACIDO 34



BOSCO 37 PAVONE 71 PETROLIO 72 MENTA 73 TURCHESE 74 RAL

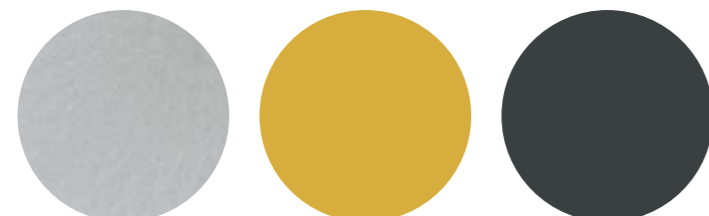

MET. ALLUMINIO 05 solo opaco MET. ORO 17 solo opaco MET. TITANIO 09 solo opaco

ARCHEDA | WOOD

• FINITURE _ WOOD

FINISHES - FINITIONS - OBERFLÄCHEN FERTIGUNGEN - ACABADOS

LACCATO METAL

METAL LAQUERED - METAL FINITION - METAL FEINBEARBEITUNGEN - ACABADOS METAL



RAME CORTEN ACCIAIO

ABETE (SOLO FRONTALE BASE)

ONLY UNIT BASE FRONT - SEULEMENT FAÇADE ÉLÉMENT BAS - NUR FÜR UNTERSCHRANKFRONT - SÒLO FRONTAL DE ELEMENTO BAJO

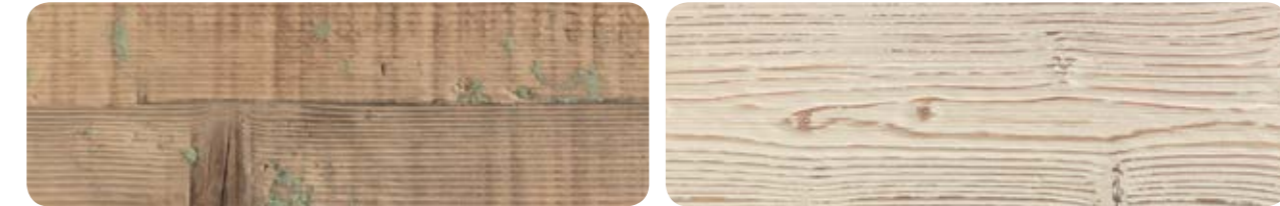

ABETE NATURALE ABETE SBIANCATO

SCocca BASE LACCATA TITANIO OPACO
STRUCTURE TITANIO MATT LAQUERED
CAISSON LAQUÉ TITANIO MAT
KORPUS LACKIERT TITANIO MATT
ESTRUCTURA LACADA TITANIO MATE

SCocca BASE LACCATA BIANCO OPACO
STRUCTURE BIANCO MATT LAQUERED
CAISSON LAQUÉ BIANCO MAT
KORPUS LACKIERT BIANCO MATT
ESTRUCTURA LACADA BIANCO MATE

ARCHEDA | WOOD



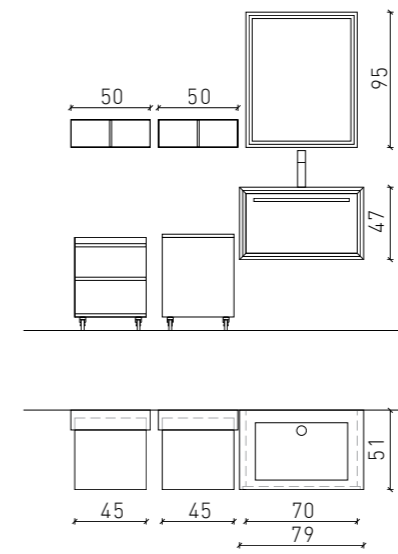

WOOD 01 - Struttura Ring Abete Naturale con base laccata Juta opaco. Lavabo Foil e specchio Back con illuminazione integrata in metallo finitura Titanio.

Abete Naturale finishing Ring structure with Juta matt lacquered base unit. Titanio metal finishing Foil washbasin and Back mirror with integrated lighting.

Structure Ring Abete Naturale avec élément bas laquée Juta mat. Vasque Foil et miroir Back avec éclairage incorporé en métal Titanio.

Struktur Ring aus Abete Naturale mit Unterschrank Juta matt lackiertes. Foil Becken und Back Spiegel mit Beleuchtung aus Metall Titanio.

Estructura Ring Abete Naturale con mueble lacado Juta mate. Cuba Foil y espejo Back con iluminacion integrada de metal pintado Titanio.





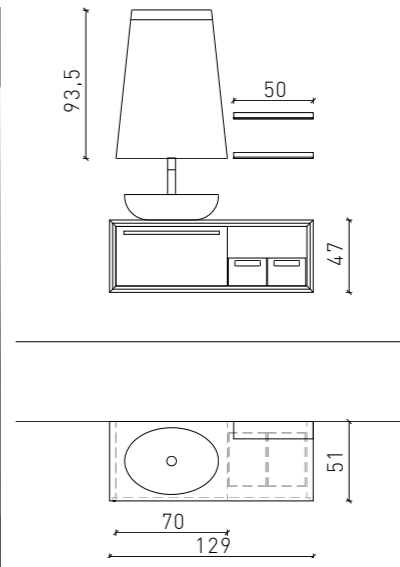

WOOD 02 - Struttura Ring Abete Naturale, base con scocca laccata Titanio opaco e frontale Abete Naturale. Lavabo Corner Nero opaco, specchio Ercole e mensole Titanio. Cestini in metallo Titanio.

Abete Naturale finishing Ring structure, base unit with Titanio matt lacquered sides and Abete Naturale frontal panel. Black matt Corner washbasin. Titanio metal Ercole mirror, shelves and baskets.

Structure Ring Abete Naturale, élément bas avec caisson laquée Titanio mat et façade en Abete Naturale. Vasque Corner noir mat, miroir Ercole, étagères et panieres en métal Titanio.

Struktur Ring aus Abete Naturale, Unterschrank mit Titanio lackiertes Korpus und Front aus Abete Naturale. Becken Corner Schwarz matt, Ercole Spiegel und Wandbordes aus Metall Titanio.

Estructura Ring Abete Naturale, mueble con estructura lacada Titanio mate y frente de abete Naturale. Cuba Corner negro mate, espejo Ercole y encimeras de metal pintado Titanio.





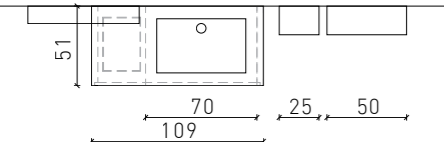
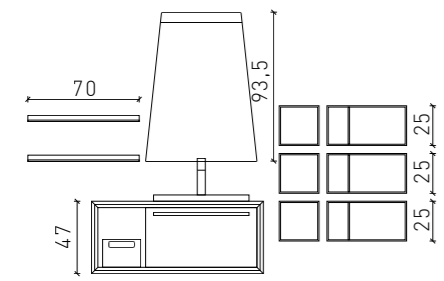

WOOD 03 - Struttura Ring Abete Sbiancato, base laccata Bianco opaco, lavabo Regolo in ceramica. Specchio Ercole, mensole e cestino in metallo Bianco.

Abete Sbiancato finishing Ring structure, Bianco matt lacquered base unit, Regolo ceramic washbasin. Bianco metal Ercole mirror, shelves and basket.

Structure Ring Abete Sbiancato, élément bas laquée Bianco mat, vasque en céramique Regolo. Miroir Ercole, étagères et panier en métal Bianco.

Struktur Ring aus Abete Sbiancato, Unterschrank Bianco matt lackierte. Regolo Becken aus Keramik, Ercole Spiegel, Wandbordes und Korb aus Metall Bianco.

Estructura Ring Abete Sbiancato con mueble lacado Bianco mate, cuba Regolo de cerámica. Espejo Ercole, estanterías y cesta de metal pintado Bianco.





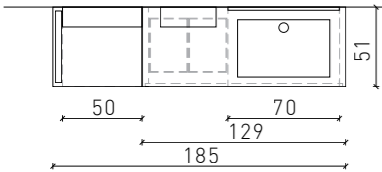
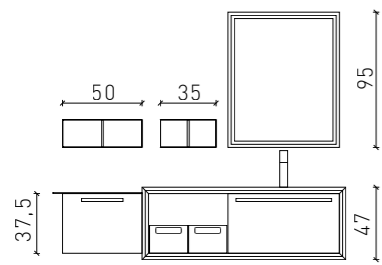

WOOD 04 - Struttura Ring Abete Naturale, basi Metal Corten. Lavabo Foil, specchio Back con illuminazione integrata, elementi a giorno e cestini in metallo Titanio.

Abete Naturale finishing Ring structure with Metal Corten lacquered base units. Titanio metal finishing Foil washbasin, Back mirror with integrated lighting open wall elements and baskets.

Structure Ring Abete Naturale, élément bas laquée Metal Corten. Vasque Foil, miroir Back avec éclairage incorporé, éléments ouverts et panier en métal Titanio.

Struktur Ring aus Abete Naturale, Unterschranke Metal Corten lackierten. Foil Becken, Back Spiegel mit Beleuchtung, offene Elemente und Korbe aus Metall Titanio.

Estructura Ring Abete Naturale, muebles lacados Metal Corten. Cuba Foil, espejo Back con iluminacion integrada, elementos abiertos y cestas de metal pintado Titanio.







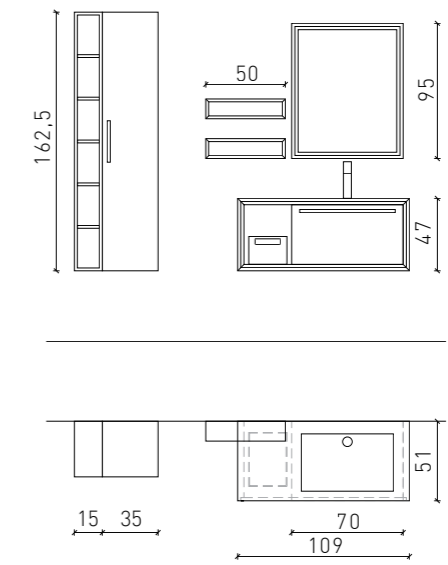

WOOD 05 - Struttura Ring Abete Sbiancato, base con scocca laccata Bianco opaco e frontale Abete Sbiancato; elementi a giorno in Tessuto laccato bianco. Lavabo Foil, specchio Back con illuminazione integrata e cestino in metallo Bianco.

Abete Sbiancato finishing Ring structure, base unit with Bianco matt lacquered sides and Abete Sbiancato frontal panel; Bianco lacquered twill open wall elements. Bianco metal finishing Foil washbasin, Back mirror with integrated lighting and basket.

Structure Ring Abete Sbiancato, élément bas avec caisson laquée Bianco mat et façade en Abete Sbiancato; éléments ouverts en Tissu laqué Bianco mat. Vasque Foil, miroir Back avec éclairage incorporé et panier en métal Bianco.

Struktur Ring aus Abete Sbiancato, Unterschrank mit Bianco matt lackiertes Korpus und Front aus Abete Sbiancato; offene Elemente aus Stoff Weiss lackiert. Foil Becken, Back Spiegel mit Beleuchtung und Korbe aus Metall Bianco.

Estructura Ring Abete Sbiancato, mueble con estructura lacada Bianco mate y frente de Abete Sbiancato; elementos abiertos de tejido lacado Bianco. Cuba Foil, espejo Back con iluminacion integrada y cesta de metal pintado Bianco.



• VARIANTI _ WOOD

L 79



• VARIANTI _ WOOD

L 109

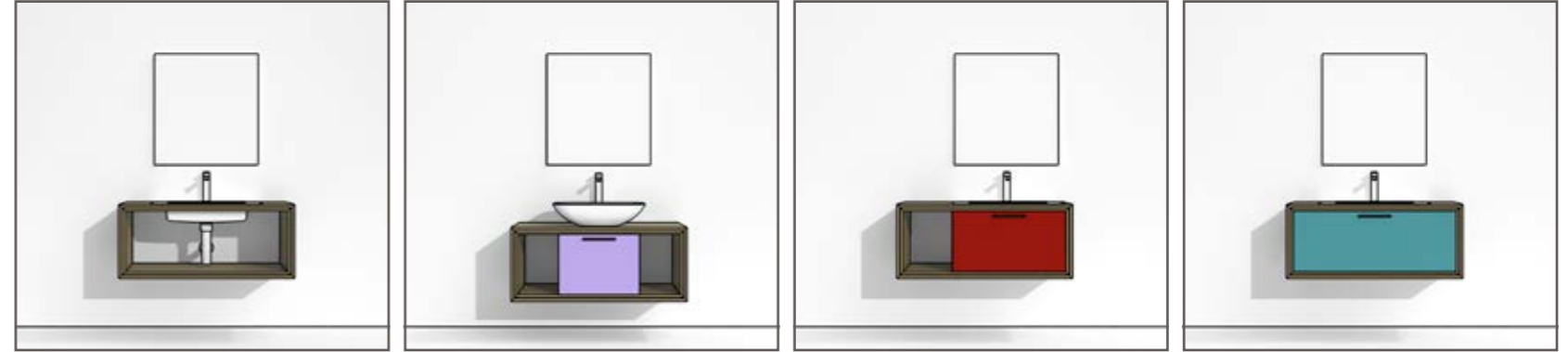

L 94

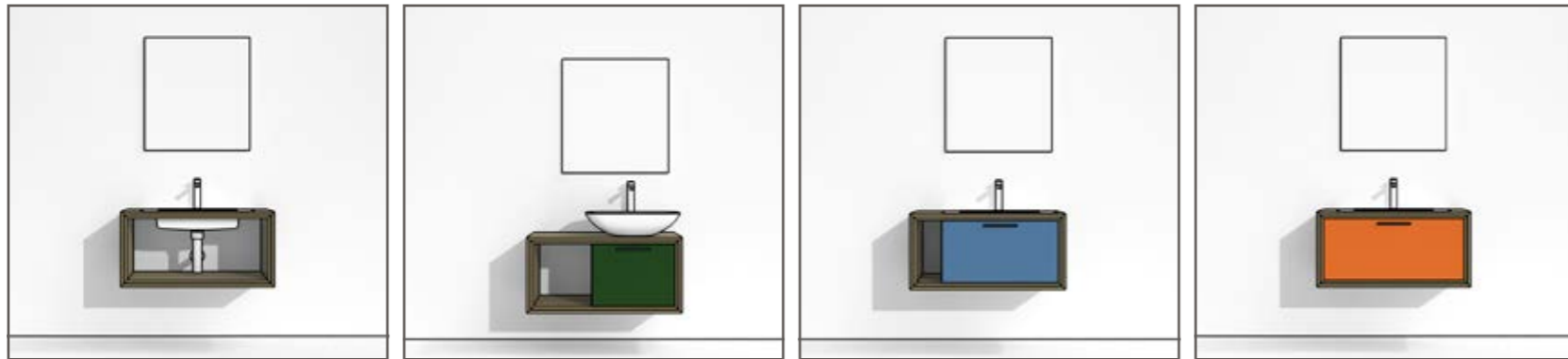

L 129

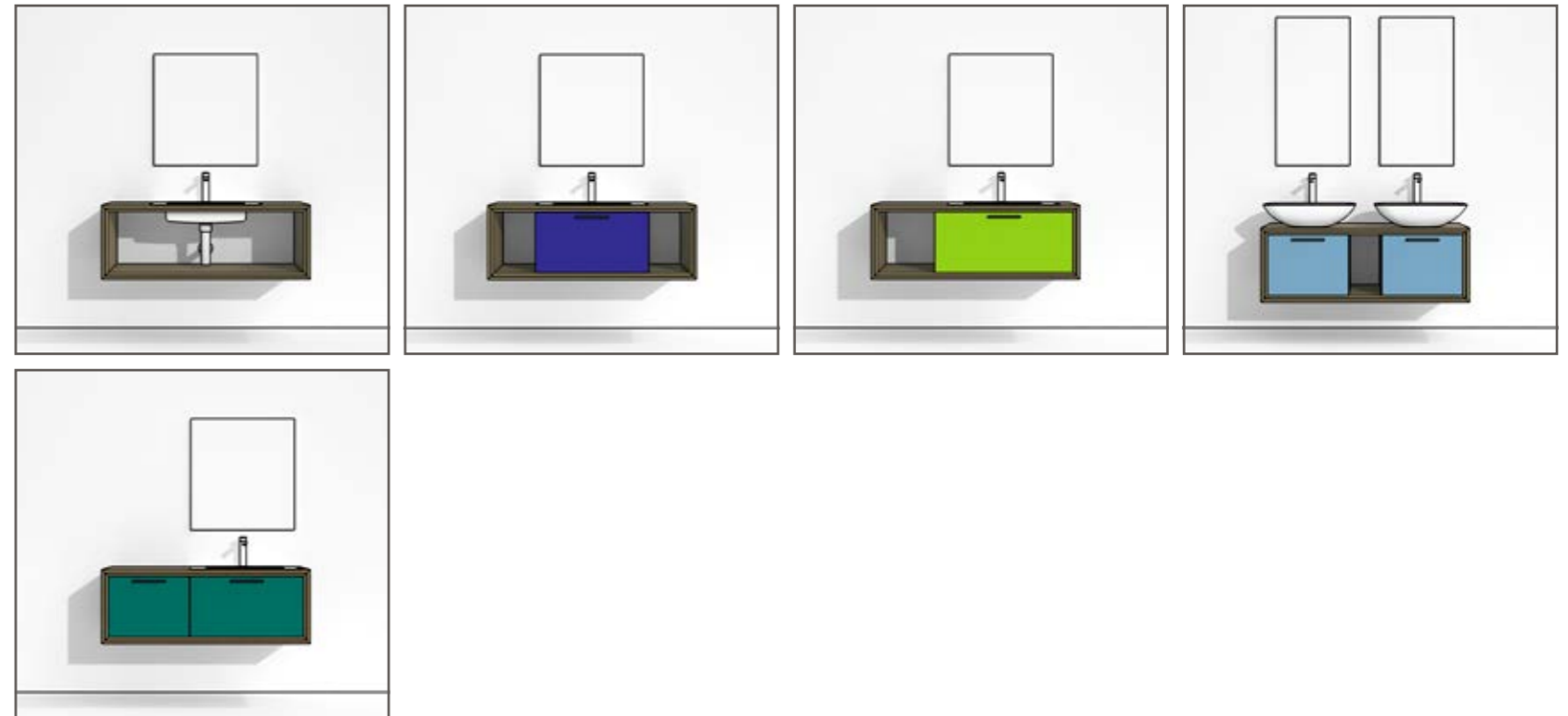

• TOP IN ABETE MASSICCIO
SOLID TIR WOODEN TOP | PLAN DE TOILETTE EN SAPIN MASSIF
WASCHTISCHPLATTE AUS MASSIVEM TANNENHOLZ | ENCIMERA DE ABETO MACIZO

TOP ABETE



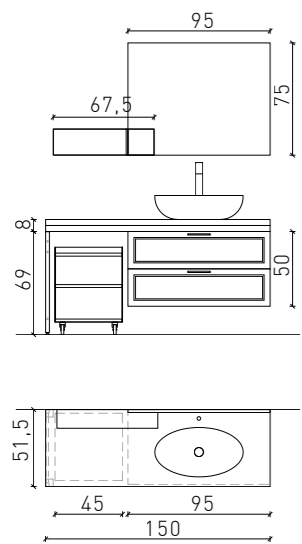

TOP ABETE



abete
naturale

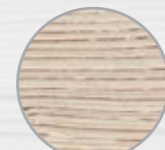

abete
sbiancato

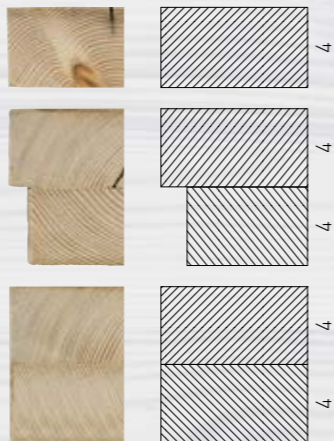

SETA 03 - Laccato TITANIO OPACO, top ABETE NATURALE sp. 8 cm con bordo rientrante, lavabo d' appoggio Softly nero opaco. Specchio FILO con lampada METRO. Elemento a giorno in finitura Titanio con schiena ZAFFERANO OPACO, carrellino con ripiani laccati TITANIO OPACO

Titanio matt lacquered, th. 8 cm ABETE NATURALE top with recessed frontal edge, Softly Black matt basin. FILO mirror with METRO lamp. Titanio open wall element with ZAFFERANO MATT lacquered back, cart with Titanio matt lacquered shelves.

Laquée TITANIO MAT, plan de toilette ABETE NATURALE ep. 8 cm avec basin SOFTLY noir mat. Miroir FILO avec lampe METRO. Élément ouvert en Titanio et ZAFFERANO MAT, chariot avec étagères Titanio.

TITANIO MATT lackiert, Waschtischplatte aus ABETE NATURALE st. 8 cm, Waschbecken SOFTLY schwarz matt. FILO Spiegel mit METRO Lampe. Offen Element aus Titanio und ZAFFERANO MATT, Wagen mit Ablagen TITANIO MATT.

Lacado BIANCO MATE, encimera de ABETE NATURALE esp. 8 cm con cuba SOFTLY negro mate. Espejo FILO con lámpara METRO. Módulo abierto de Titanio con posterior lacado ZAFFERANO MATE, carrito con estantes TITANIO MATE





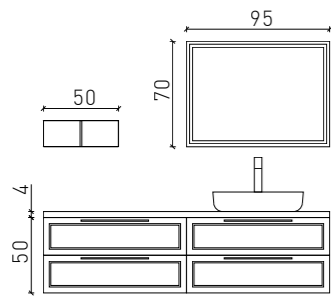

SETA 08 - Laccato BIANCO OPACO, top ABETE SBIANCATO sp. 4 cm con lavabo d'appoggio COVER nero opaco. Specchio BACK in finitura Titanio. Colonne con scocca laccata Titanio opaco, ante telaio alluminio finitura Titanio e vetro fumé.

BIANCO WHITE lacquered, th. 4 cm ABETE SBIANCATO top with black matt COVER basin. Titanio BACK mirror. Titanio matt lacquered towers with titanio aluminium frame and fumé glass.

Laquée BIANCO MAT, plan de toilette ABETE SBIANCATO ep. 4 cm avec basin COVER noir mat. Miroir BACK titanio. Colonne laquée TITANIO MAT avec cadre en aluminium Titanio et verre fumé.

BIANCO MATT lackiert. Waschtischplatte aus ABETE SBIANCATO St. 4 cm mit COVER schwarz matt Waschbecken. Titanio BACK Spiegel. Hochschranke TITANIO MATT lackierten mit Aluminium Profil Titanio und geräuchert Glas.

Lacado BIANCO MATE, encimera de ABETE SBIANCATO esp. 4 cm con cuba COVER negro mate. Espejo BACK en acabado Titanio. Columnas lacadas TITANIO MATE con puerta con marco de aluminio Titanio y cristal ahumado.

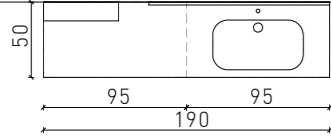

- TOP IN ROVERE MASSICCIO
CON BORDO FRONTALE CORTECCIA

SOLID OAK WOODEN TOP WITH BARK-LIKE FRONTAL EDGE

PLAN DE TOILETTE EN CHÊNE MASSIF AVEC BORD FRONTAL EFFET ÉCORCE BRUTE

WASCHTISCHPLATTE AUS MASSIVEM EICHENHOLZ MIT VONDERKANTE ALS RINDE

ENCIMERA DE ROBLE MACIZO CON ORILLO FRONTAL SIMILAR CORTEZA

TOP CORTECCIA

• I MATERIALI _ CORTECCIA

OUR MATERIALS _ "CORTECCIA" - LES MATÉRIAUX CORTECCIA - DIE MATERIALIEN _ CORTECCIA - LOS MATERIALES _ CORTEZA

I top CORTECCIA sono realizzati con legno di Rovere massiccio tinto naturale. Sono formati da 2/3 tavole assemblate una all'altra per ottenere la profondità desiderata; quella frontale presenterà il caratteristico bordo a CORTECCIA e darà la forma irregolare al piano. Queste tavole sono ricavate da alberi morenti e da pulizie boschive, non vengono quindi abbattuti alberi sani e vivi per la realizzazione dei nostri top. Ogni top sarà unico nel suo genere in quanto formato da tavolame disomogeneo nelle dimensioni, nelle colorazioni e nella venatura; potrà presentare quindi NODI, STRIATURE e LEGGERE CREPE.

Our "CORTECCIA" tops are made from natural stained solid Oak wood. They consist of 2/3 planks assembled together to obtain the desired depth. The front plank has a distinctive BARK edge which gives the top its irregular shape. These planks come from trees that are dying and from forest cleaning operations. No healthy trees are felled to make our tops. Each top is unique in its kind because it is made using planks of different sizes, colours and with different wood grains. It may therefore feature KNOTS, STREAKS and FINE CRACKS.

Les plans de toilette CORTECCIA sont réalisés en chêne massif teinté naturel. Ils se forment de 2/3 planches assemblées pour obtenir la profondeur souhaitée. La planche de devant a le caractère chant ÉCORCE qui donne au plan de toilette sa forme irrégulière. Ces planches proviennent d'arbres mourants et de nettoyages de forêts. Aucun arbre sain et vivant n'est donc abattu pour la réalisation de nos plans de travail. Chaque plan sera unique en son genre puisqu'il se forme de planches toutes différentes les unes des autres au niveau de la dimension, de la teinte et des veines. En effet, celles-ci pourront avoir des NŒUDS, DES STRIES et de LÉGÈRES FENTES.

Die Waschtischplatten CORTECCIA werden aus massivem Eichenholz in Farbe Natur hergestellt. Sie bestehen aus 2/3 Brettern, die zur Erreichung der gewünschten Tiefe aneinandergesetzt werden. Das vordere Brett weist die charakteristische Kante RINDE-KANTE auf und führt zur unregelmäßigen Form der Platte. Diese Bretter stammen von sterbenden Bäumen bzw. aus Waldpflegearbeiten, zur Herstellung unserer Waschtischplatten müssen also keine gesunden und lebenden Bäume gefällt werden. Jede Waschtischplatte ist einzigartig in ihrer Art, da die verwendeten Holzbretter hinsichtlich Maße, Farben und Maserung unterschiedlich sind. Es können daher ASTLÖCHER, STREIFEN und LEICHTE RISSE auftreten.

Las encimeras CORTECCIA están realizadas con madera maciza de Roble teñido natural. Están formadas por 2/3 tablas juntadas hasta obtener la medida de fondo requerida; la delantera tiene el característico canto en CORTEZA que confiere a la encimera su forma irregular. Estas tablas se obtienen de árboles que están muriendo y de la limpieza del bosque, por tanto nunca se talan árboles vivos para la realización de nuestras encimeras. Cada encimera es única en su género porque está formada por tablas desiguales por lo que a tamaño, color y veta se refiere; por tanto podrá tener NUDOS, ESTRIACIONES y LEVES HENDIDURAS.

• TOP _ CORTECCIA



GOLA 37 - Top rovere Corteccia, lavabo Blocco in marmo Emperador Dark, specchio Ercole in titanio, elementi a giorno con schiena in Nordico Naturale

Corteccia top, Emperador Dark marble Blocco basin, mirror Ercole, open elements with Nordico Naturale back

Plan de toilette Corteccia, lavabo Blocco en marbre Emperador Dark, miroir Ercole, éléments ouverts en Nordico Naturale

Waschtischplatte Corteccia, Blocco Becken aus Emperador Dark Marmor, Spiegel Ercole, offene Elemente aus Nordico Naturale

Encimera Corteccia, cuba Blocco de mármol Emperador Dark, espejo Ercole, módulos abiertos de Nordico Naturale

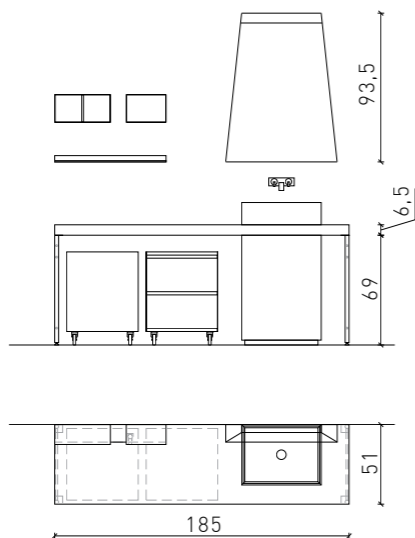

GOLA COMP 37

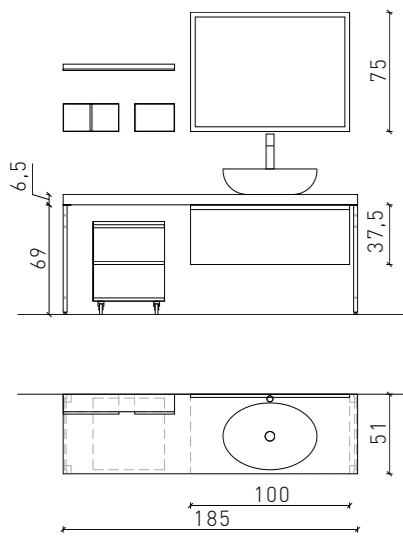

GOLA 38 - Laccato Nero opaco e Nordico Naturale, top rovere Corteccia, lavabo Softly Nero opaco, specchio Luna

Nero matt lacquered and Nordico Naturale, top Corteccia, Softly black matt basin, mirror Luna

Laquée Nero mat, plan de toilette Corteccia, vasque à poser Softly noir mat, miroir Luna

Nero matt lackierte, Waschtischplatte Corteccia, Becken Softly Schwarz matt, Spiegel Luna

Lacado Nero mate, encimera Corteccia, cuba Softly negro mate, espejo Luna



GOLA COMP 38

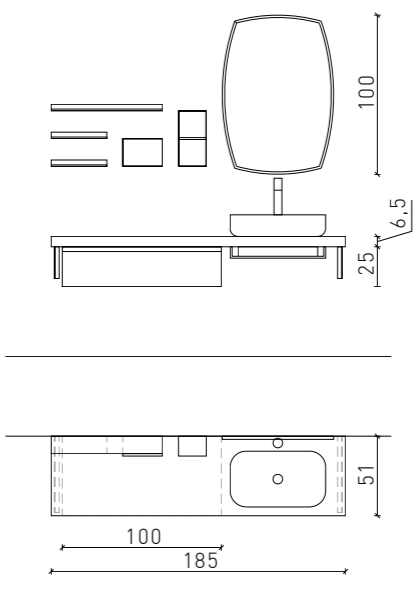

GOLA 39 - Laccato Liquirizia opaco e Rovere Nordico Naturale, top rovere Corteccia, lavabo Elite, specchio Vintage

Liquirizia matt lacquered and Nordico Naturale, top Corteccia, Elite basin, mirror Vintage

Laquée Liquirizia mat, plan de toilette Corteccia, vasque à poser Elite, miroir Vintage

Liquirizia matt lackierte, Waschtischplatte Corteccia, Becken Elite, Spiegel Vintage

Lacado Liquirizia mate, encimera Corteccia, cuba Elite, espejo Vintage



GOLA COMP 39



26	CUSCINETTO 25X62X17 SKF 7305BE	2
25	CUSCINETTO 12X37X12 SKF 7301BE	1
	CUSCINETTO 15X42X13 SKF 7302BE	2

A	17 X 30 UNI 6592	1
ITA	13 X 24 UNI 6592	6

METALLO

• ACCESSORI IN METALLO
METAL COMPLEMENTS | COMPLEMENTS EN MÉTAL
KOMPLEMENTE AUS METAL | COMPLEMENTOS DE METAL

1 | Specchio ERCOLE TITANIO
Mirror ERCOLE TITANIO
Miroir ERCOLE TITANIO
Spiegel ERCOLE TITANIO
Espejo ERCOLE TITANIO

3 | Mensole ERCOLE TITANIO
ERCOLE TITANIO shelves
Étagères ERCOLE TITANIO
Wandbord ERCOLE TITANIO
Repisas ERCOLE TITANIO

5 | Portasalviette da fianco
Side towelholder
Porte-serviettes
Handtuchhalter
Toallero

7 | Portasalviette per top
Top towelholder
Porte-serviettes pour plan de toilette
Handtuchhalter für Tischplatte
Toallero para encimera

10 | Portalavabo in metallo BANKO
Metal washbasin unit BANKO
Élément sous vasque en metal BANKO
Waschtisch-Unterschrank aus Metall BANKO
Módulo de metal por lavabo BANKO

12 | Lavabo FOIL
Washbasin FOIL
Lavabo FOIL
Becken FOIL
Cuba FOIL

14 | Carrello con ripiani
Shelves cart
Chariot avec étagères
Wagen mit Ablagen
Carrito con estantes

17 | Scaletta O-ISSA
O-ISSA ladder
Échelle O-ISSA
Leiter O-ISSA
Escalera O-ISSA

2 | Specchio BACK TITANIO
Mirror BACK TITANIO
Miroir BACK TITANIO
Spiegel BACK TITANIO
Espejo BACK TITANIO

4 | Elementi a giorno
Open wall units
Éléments à jour
Offene Elemente
Elementos abiertos

6 | Top con portasalviette
Top with towelholder
Plan de toilette avec porte-serviettes
Tisch-platte mit Handtuchhalter
Encimera con toallero

8 | Staffa sostegno top
Top support bracket
Console de support pour plan de toilette
Halterung für Waschtische
Escuadra de soporte para encimera

11 | Carrelli
Carts
Chariots
Wagen
Carritos

13 | Sgabello ERGO
Stool ERGO
Tabouret ERGO
Hocker ERGO
Escabel ERGO

15 | Carrello portabiancheria
Laundry cart
Chariot Buanderie
Wäschekorb auf Räder
Carrito para lencería

16 | Cestino metallo forato
Hole metal basket
Panier de metal perforé
Korb aus perforiertes metall
Cesta de metal perforado



ACCESSORI METALLO



SETA 02 - BANKO in finitura Titanio con contenitore ad anta in finitura ROVERE FIAMMATO GRANO, lavabo in ceramica CUBO, specchio BACK TITANIO. Elementi a giorno e carrellini Titanio con particolari Nordico Naturale

Titanio finish BANKO with door element on FIAMMATO GRANO OAK, ceramic washbasin CUBO, Titanio BACK mirror. Open wall elements and shelves cart with Nordico Naturale details.

BANKO en finition Titanio avec porte en chêne Fiammato GRANO, plan-vasque CUBO en céramique, miroir BACK Titanio. Élément ouvert et chariot avec détails en Nordico Naturale.

BANKO aus Titanio Fertigung mit Tür Eiche Fiammato GRANO, Waschbecken aus Keramik CUBO, BACK Titanio Spiegel. Offene Elemente und Wagen Titanio mit Nordico Naturale Fertigungen.

BANKO en acabado Titanio con puerta de Roble Fiammato GRANO, consola CUBO de cerámica, espejo Titanio BACK. Módulo abierto y carrito con detalles de Nordico Naturale.

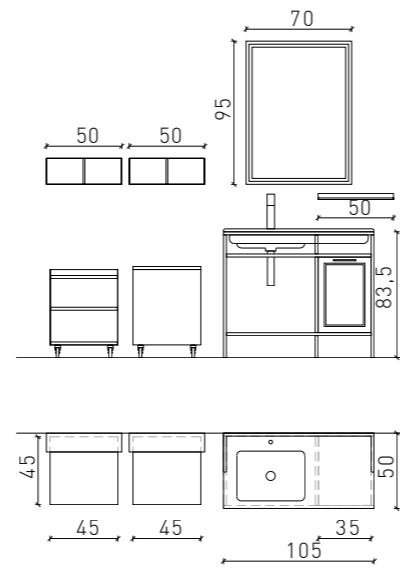

CATALOGUE PLANNIG
Maurizio Poletto

DESIGN E A.D.
Dario Poles

GRAPHIC DESIGN CATALOGO
Graphosds

FOTOGRAFIA
Gabriotti Fotografi

FOTOLITO E STAMPA
graficheitalprint.it

OTTOBRE 2017

Archeda, al fine di migliorare le caratteristiche tecniche e qualitative della sua produzione, si riserva di apportare, anche senza preavviso, tutte le modifiche che si rendessero necessarie.

To improve the technical and the qualitative characteristics of the production, Archeda reserves the right to make all the suitable modifications without previous notice.

A fin daméliorer les caractéristiques techniques et qualitatives de sa production, la société Archeda se réserve le droit d'apporter, même sans preavis, toutes les modifications qui seront jugées nécessaires.

Um technische und qualitative Merkmale der Produktion zu verbessern, behält sich Archeda vor, alle nötige Abänderungen, ohne Avisierungen, vorzunehmen.

Archeda, a fin de mejorar las características técnicas y cualitativas de su producción, se reserva el derecho de aportar, incluso sin previo aviso, todas las modificaciones necesarias.





ARCHEDA s.r.l. via A. Malignani, 7 33080 Porcia (Pn) www.archeda.eu